

STATE OF TEXAS  
COUNTY OF HARRIS

WE, WOODMERE DEVELOPMENT CO., LTD., A TEXAS LIMITED PARTNERSHIP, ACTING BY AND THROUGH, RICHARD RUE, PRESIDENT AND JASON ERVIN, CFO, BEING OFFICERS OF WOODMERE GP, L.L.C., A TEXAS LIMITED LIABILITY COMPANY, ITS GENERAL PARTNER, OWNERS HEREINAFTER REFERRED TO AS OWNERS OF THE 14.938 ACRE TRACT DESCRIBED IN THE ABOVE AND FOREGOING MAP OF WESTFIELD RANCH SEC 5, DO HEREBY MAKE AND ESTABLISH SAID SUBDIVISION AND DEVELOPMENT PLAN OF SAID PROPERTY ACCORDING TO ALL LINES, DEDICATIONS, RESTRICTIONS, AND NOTATIONS ON SAID MAPS OR PLAT, AND HEREBY DEDICATE TO THE USE OF THE PUBLIC FOREVER, ALL STREETS (EXCEPT THOSE STREETS DESIGNATED AS PRIVATE STREETS, OR PERMANENT ACCESS EASEMENTS), ALLEYS, PARKS, WATER COURSES, DRAINS, EASEMENTS, AND PUBLIC PLACES SHOWN THEREON FOR THE PURPOSES AND CONSIDERATIONS THEREIN EXPRESSED; AND DO HEREBY BIND OURSELVES, OUR HEIRS, SUCCESSORS, AND ASSIGNS TO WARRANT AND FOREVER DEFEND THE TITLE ON THE LAND SO DEDICATED.

FURTHER, OWNERS HAVE DEDICATED AND BY THESE PRESENTS DO DEDICATE TO THE USE OF THE PUBLIC FOR PUBLIC UTILITY PURPOSES FOREVER UNOBSTRUCTED AERIAL EASEMENTS. THE AERIAL EASEMENTS SHALL EXTEND HORIZONTALLY AN ADDITIONAL ELEVEN FEET, SIX INCHES (11' 6") FOR TEN FEET (10' 0") PERIMETER GROUND EASEMENTS OR SEVEN FEET, SIX INCHES (7' 6") FOR FOURTEEN FEET (14' 0") PERIMETER GROUND EASEMENTS OR FIVE FEET, SIX INCHES (5' 6") FOR SIXTEEN FEET (16' 0") PERIMETER GROUND EASEMENTS, FROM A PLANE SIXTEEN FEET (16' 0") ABOVE THE GROUND LEVEL UPWARD, LOCATED ADJACENT TO AND ADJOINING SAID PUBLIC UTILITY EASEMENTS THAT ARE DESIGNATED WITH AERIAL EASEMENTS (U.E. AND A.E.) AS INDICATED AND DEPICTED HEREON, WHEREBY THE AERIAL EASEMENT TOTALS TWENTY ONE FEET, SIX INCHES (21' 6") IN WIDTH.

FURTHER, OWNERS HAVE DEDICATED AND BY THESE PRESENTS DO DEDICATE TO THE USE OF THE PUBLIC FOR PUBLIC UTILITY PURPOSES FOREVER UNOBSTRUCTED AERIAL EASEMENTS. THE AERIAL EASEMENTS SHALL EXTEND HORIZONTALLY AN ADDITIONAL TEN FEET (10' 0") FOR TEN FEET (10' 0") BACK-TO-BACK GROUND EASEMENTS, OR EIGHT FEET (8' 0") FOR FOURTEEN FEET (14' 0") BACK-TO-BACK GROUND EASEMENTS OR SEVEN FEET (7' 0") FOR SIXTEEN FEET (16' 0") BACK-TO-BACK GROUND EASEMENTS, FROM A PLANE SIXTEEN FEET (16' 0") ABOVE THE GROUND LEVEL UPWARD, LOCATED ADJACENT TO BOTH SIDES AND ADJOINING SAID PUBLIC UTILITY EASEMENTS THAT ARE DESIGNATED WITH AERIAL EASEMENTS (U.E. AND A.E.) AS INDICATED AND DEPICTED, HEREON, WHEREBY THE AERIAL EASEMENT TOTALS THIRTY FEET (30' 0") IN WIDTH.

FURTHER, OWNERS DO HEREBY DECLARE THAT ALL PARCELS OF LAND DESIGNATED AS LOTS ON THIS PLAT ARE ORIGINALLY INTENDED FOR THE CONSTRUCTION OF SINGLE FAMILY RESIDENTIAL DWELLING UNITS THEREON AND SHALL BE RESTRICTED FOR SAME UNDER THE TERMS AND CONDITIONS OF SUCH RESTRICTIONS FILED SEPARATELY.

FURTHER, OWNERS DO HEREBY COVENANT AND AGREE THAT ALL OF THE PROPERTY WITHIN THE BOUNDARIES OF THIS PLAT IS HEREBY RESTRICTED TO PREVENT THE DRAINAGE OF ANY SEPTIC TANKS INTO ANY PUBLIC OR PRIVATE STREET, PERMANENT ACCESS EASEMENT, ROAD OR ALLEY, OR ANY DRAINAGE DITCH, EITHER DIRECTLY OR INDIRECTLY.

FURTHER, OWNERS DO HEREBY DEDICATE TO THE PUBLIC A STRIP OF LAND FIFTEEN FEET (15' 0") WIDE ON EACH SIDE OF THE CENTER LINE OF ANY AND ALL BAYOUS, CREEKS, GULLIES, RAVINES, DRAWS, SLOUGHS OR OTHER NATURAL DRAINAGE COURSES LOCATED IN SAID PLAT, AS EASEMENTS FOR DRAINAGE PURPOSES, GIVING THE CITY OF HOUSTON, HARRIS COUNTY, OR ANY OTHER GOVERNMENTAL AGENCY, THE RIGHT TO ENTER UPON SAID EASEMENT AT ANY AND ALL TIMES FOR THE PURPOSE OF CONSTRUCTION AND MAINTENANCE OF DRAINAGE FACILITIES AND STRUCTURES.

FURTHER, OWNERS DO HEREBY COVENANT AND AGREE THAT ALL OF THE PROPERTY WITHIN THE BOUNDARIES OF THIS PLAT AND ADJACENT TO ANY DRAINAGE EASEMENT DITCH, GULLY, CREEK OR NATURAL DRAINAGE WAY SHALL HEREBY BE RESTRICTED TO KEEP SUCH DRAINAGE WAYS AND EASEMENTS CLEAR OF FENCES, BUILDINGS, PLANTING AND OTHER OBSTRUCTIONS TO THE OPERATIONS AND MAINTENANCE OF THE DRAINAGE FACILITY AND THAT SUCH ABUTTING PROPERTY SHALL NOT BE PERMITTED TO DRAIN DIRECTLY INTO THIS EASEMENT EXCEPT BY MEANS OF AN APPROVED DRAINAGE STRUCTURE.

FURTHER, OWNERS CERTIFY AND COVENANT THAT THEY HAVE COMPLIED WITH OR WILL COMPLY WITH EXISTING HARRIS COUNTY ROAD LAW, SECTION 31-C AS AMENDED BY CHAPTER 614, ACTS OF 1973, 63rd LEGISLATURE AND ALL OTHER REGULATIONS HERETOFORE ON FILE WITH THE HARRIS COUNTY ENGINEER AND ADOPTED BY THE COMMISSIONERS' COURT OF HARRIS COUNTY.

IN TESTIMONY WHEREOF, WOODMERE DEVELOPMENT CO., LTD., A TEXAS LIMITED PARTNERSHIP, BY WOODMERE GP, L.L.C., A TEXAS LIMITED LIABILITY COMPANY, ITS GENERAL PARTNER, HAS CAUSED THESE PRESENTS TO BE SIGNED BY RICHARD RUE, ITS PRESIDENT, THEREUNTO AUTHORIZED, ATTESTED BY ITS CFO JASON ERVIN.

THIS 19th DAY OF December, 2019.

WOODMERE DEVELOPMENT CO., LTD.,  
A TEXAS LIMITED PARTNERSHIP

BY: WOODMERE GP, L.L.C.,  
A TEXAS LIMITED LIABILITY COMPANY  
ITS GENERAL PARTNER

BY: *Richard Rue*  
RICHARD RUE, PRESIDENT

ATTEST: *Jason Ervin*  
JASON ERVIN, CFO

STATE OF TEXAS  
COUNTY OF HARRIS

BEFORE ME, THE UNDERSIGNED AUTHORITY, ON THIS DAY PERSONALLY APPEARED JASON ERVIN, CFO AND RICHARD RUE, PRESIDENT WOODMERE GP, L.L.C., A TEXAS LIMITED LIABILITY COMPANY, GENERAL PARTNER OF WOODMERE DEVELOPMENT CO., LTD., A TEXAS LIMITED PARTNERSHIP, KNOWN TO ME TO BE THE PERSONS WHOSE NAMES ARE SUBSCRIBED TO THE FOREGOING INSTRUMENT AND ACKNOWLEDGED TO ME THAT THEY EXECUTED THE SAME FOR THE PURPOSES AND CONSIDERATIONS THEREIN EXPRESSED, AND IN THE CAPACITY THEREIN AND HEREIN STATED, AND AS THE ACT AND DEED OF SAID CORPORATION, GIVEN UNDER MY HAND AND SEAL OF OFFICE.

THIS 19th DAY OF December, 2019.

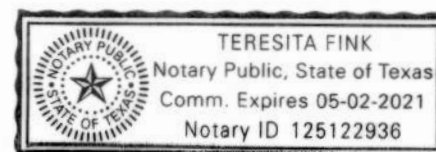

*Teresita Fink*  
NOTARY PUBLIC IN AND FOR THE  
STATE OF TEXAS  
MY COMMISSION EXPIRES: 05-02-2021

I, BRIAN NAWARA, AM AUTHORIZED (OR REGISTERED) UNDER THE LAWS OF THE STATE OF TEXAS TO PRACTICE THE PROFESSION OF SURVEYING AND HEREBY CERTIFY THAT THE ABOVE SUBDIVISION IS TRUE AND ACCURATE; WAS PREPARED FROM AN ACTUAL SURVEY OF THE PROPERTY MADE UNDER MY SUPERVISION ON THE GROUND; THAT, EXCEPT AS SHOWN ALL BOUNDARY CORNERS, ANGLE POINTS, POINTS OF CURVATURE AND OTHER POINTS OF REFERENCE HAVE BEEN MARKED WITH IRON (OR OTHER OBJECTS OF A PERMANENT NATURE) PIPES OR RODS HAVING A DIAMETER OF NOT LESS THAN FIVE EIGHTHS (5/8) INCH AND A LENGTH OF NOT LESS THAN THREE (3) FEET; AND THAT THE PLAT BOUNDARY CORNERS HAVE BEEN TIED TO THE TEXAS COORDINATE SYSTEM OF 1983, SOUTH CENTRAL ZONE.



*Brian Nawara*  
BRIAN NAWARA  
REGISTERED PROFESSIONAL LAND SURVEYOR  
TEXAS REGISTRATION NO. 6060

THIS IS TO CERTIFY THAT THE PLANNING COMMISSION OF THE CITY OF HOUSTON, TEXAS, HAS APPROVED THIS PLAT AND SUBDIVISION OF WESTFIELD RANCH SEC 5 IN CONFORMANCE WITH THE LAWS OF THE STATE OF TEXAS AND THE ORDINANCES OF THE CITY OF HOUSTON, AS SHOWN HEREON, AND AUTHORIZED THE RECORDING OF THIS PLAT

THIS 7th DAY OF January, 2020.

BY: *Martina Stein*  
MARTHA L. STEIN, CHAIRMAN OR  
SONNY GAZZA, VICE CHAIRMAN



BY: *Margaret Wallace Brown*  
MARGARET WALLACE BROWN, AICP, CNU-A, SECRETARY

I, JOHN R. BLOUNT, COUNTY ENGINEER OF HARRIS COUNTY, HEREBY CERTIFY THAT THE PLAT OF THIS SUBDIVISION COMPLIES WITH ALL THE EXISTING RULES AND REGULATIONS OF THIS OFFICE AS ADOPTED BY THE HARRIS COUNTY COMMISSIONERS' COURT AND THAT IT COMPLIES OR WILL COMPLY WITH ALL APPLICABLE PROVISIONS OF THE HARRIS COUNTY ROAD LAW AS AMENDED AND ALL OTHER COURT ADOPTED DRAINAGE REQUIREMENTS.

*John R. Blount*  
JOHN R. BLOUNT, P.E., LEED AP  
COUNTY ENGINEER

I, DIANE TRAUTMAN, COUNTY CLERK OF HARRIS COUNTY AND EX OFFICIO CLERK OF THE HARRIS COUNTY COMMISSIONERS' COURT, DO HEREBY CERTIFY THAT THE WITHIN INSTRUMENT WAS APPROVED AT A LEGALLY CONVENED MEETING OF THE HARRIS COUNTY COMMISSIONERS'

COURT HELD ON February 11, 2020 BY AN ORDER ENTERED INTO THE MINUTES OF THE COURT.



DIANE TRAUTMAN  
COUNTY CLERK  
OF HARRIS COUNTY, TEXAS

BY: *Thalia Lopez*  
THALIA LOPEZ  
DEPUTY



I, DIANE TRAUTMAN, COUNTY CLERK OF HARRIS COUNTY, DO HEREBY CERTIFY THAT THE WITHIN INSTRUMENT WITH ITS CERTIFICATE OF AUTHENTICATION WAS FILED FOR REGISTRATION IN MY OFFICE

ON February 13, 2020, AT 12:18 O'CLOCK P.M., AND DULY RECORDED

ON February 13, 2020, AT 2:11 O'CLOCK P.M., AND AT FILM CODE

NUMBER 690594 OF THE MAP RECORDS OF HARRIS COUNTY FOR SAID COUNTY.

WITNESS MY HAND AND SEAL OF OFFICE, AT HOUSTON, THE DAY AND DATE LAST ABOVE WRITTEN.

ANY PROVISION HEREIN WHICH RESTRICTS THE SALE, RENTAL OR USE OF THE DESCRIBED REAL PROPERTY BECAUSE OF COLOR OR RACE IS INVALID AND UNENFORCEABLE UNDER FEDERAL LAW.

DIANE TRAUTMAN  
COUNTY CLERK  
OF HARRIS COUNTY, TEXAS

BY: *Christian Orna*  
CHRISTIAN ORNA  
DEPUTY

NOTES:

1. THE RADIUS ON ALL BLOCK CORNERS IS 25.00 FEET, UNLESS OTHERWISE NOTED.
2. ALL EASEMENTS ARE CENTERED ON LOT LINES UNLESS OTHERWISE SHOWN.
3. THE COORDINATES SHOWN HEREON ARE TEXAS SOUTH CENTRAL ZONE NO. 4204 STATE PLANE GRID COORDINATES (NAD83) AND MAY BE BROUGHT TO SURFACE BY DIVIDING THE COMBINED SCALE FACTOR OF 0.99990830.
4. ALL BEARINGS ARE BASED ON THE TEXAS COORDINATE SYSTEM, SOUTH CENTRAL ZONE (4204).
5. UNLESS OTHERWISE INDICATED, THE BUILDING LINES (BL), WHETHER ONE OR MORE, SHOWN ON THIS SUBDIVISION PLAT ARE ESTABLISHED TO EVIDENCE COMPLIANCE WITH THE APPLICABLE PROVISIONS OF CHAPTER 42, CODE OF ORDINANCES, CITY OF HOUSTON, TEXAS, IN EFFECT AT THE TIME THIS PLAT WAS APPROVED, WHICH MAY BE AMENDED FROM TIME TO TIME.
6. SINGLE FAMILY RESIDENTIAL SHALL MEAN THE USE OF A LOT WITH ONE BUILDING DESIGNED FOR AND CONTAINING NOT MORE THAN TWO SEPARATE UNITS WITH FACILITIES FOR LIVING, SLEEPING, COOKING, AND EATING THEREIN. A LOT UPON WHICH IS LOCATED A FREE-STANDING BUILDING CONTAINING ONE DWELLING UNIT AND A DETACHED SECONDARY DWELLING UNIT OF NOT MORE THAN 900 SQUARE FEET ALSO SHALL BE CONSIDERED SINGLE FAMILY RESIDENTIAL. A BUILDING THAT CONTAINS ONE DWELLING UNIT ON ONE LOT THAT IS CONNECTED BY A PARTY WALL TO ANOTHER BUILDING CONTAINING ONE DWELLING UNIT ON AN ADJACENT LOT SHALL BE SINGLE FAMILY RESIDENTIAL.
7. EACH LOT SHALL PROVIDE A MINIMUM OF TWO OFF-STREET PARKING SPACES PER DWELLING UNIT ON EACH LOT. IN THOSE INSTANCES WHERE A SECONDARY UNIT IS PROVIDED ONLY ONE ADDITIONAL SPACE SHALL BE PROVIDED.
8. A MINIMUM OF TEN (10) FEET SHALL BE PROVIDED BETWEEN SIDES OF RESIDENTIAL DWELLINGS.
9. THIS PLAT REQUIRES COMPLIANCE WITH LANDSCAPING REQUIREMENTS PRIOR TO OCCUPANCY OF STRUCTURES AS MANDATED IN "REGULATIONS OF HARRIS COUNTY, TEXAS FOR THE APPROVAL AND ACCEPTANCE OF INFRASTRUCTURE."
10. INDICATES STREET NAME CHANGE SYMBOL
11. ANY NEW DEVELOPMENT WITHIN THE SUBDIVISION PLAT SHALL OBTAIN A STORM WATER QUALITY PERMIT BEFORE THE ISSUANCE OF ANY DEVELOPMENT PERMITS.
12. ABSENT WRITTEN AUTHORIZATION BY THE AFFECTED UTILITIES, ALL UTILITY AND AERIAL EASEMENTS MUST BE KEPT UNOBSTRUCTED FROM ANY NON-UTILITY IMPROVEMENTS OR OBSTRUCTIONS BY THE PROPERTY OWNER. ANY UNAUTHORIZED IMPROVEMENTS OR OBSTRUCTIONS MAY BE REMOVED BY ANY PUBLIC UTILITY AT THE PROPERTY OWNER'S EXPENSE. WHILE WOODEN POSTS AND paneled WOODEN FENCES ALONG THE PERIMETER AND BACK TO BACK EASEMENTS AND ALONGSIDE REAR LOTS LINES ARE PERMITTED, THEY TOO MAY BE REMOVED BY PUBLIC UTILITIES AT THE PROPERTY OWNER'S EXPENSE SHOULD THEY BE AN OBSTRUCTION. PUBLIC UTILITIES MAY PUT SAID WOODEN POSTS AND paneled WOODEN FENCES BACK UP, BUT GENERALLY WILL NOT REPLACE WITH NEW FENCING.
13. ALL LOTS SHALL HAVE ADEQUATE WASTEWATER COLLECTION SERVICE.

RP-2020-67034

2/13/2020 hccprp3 160.00

FILED

2/13/2020 12:18 PM

*Diane Trautman*  
COUNTY CLERK

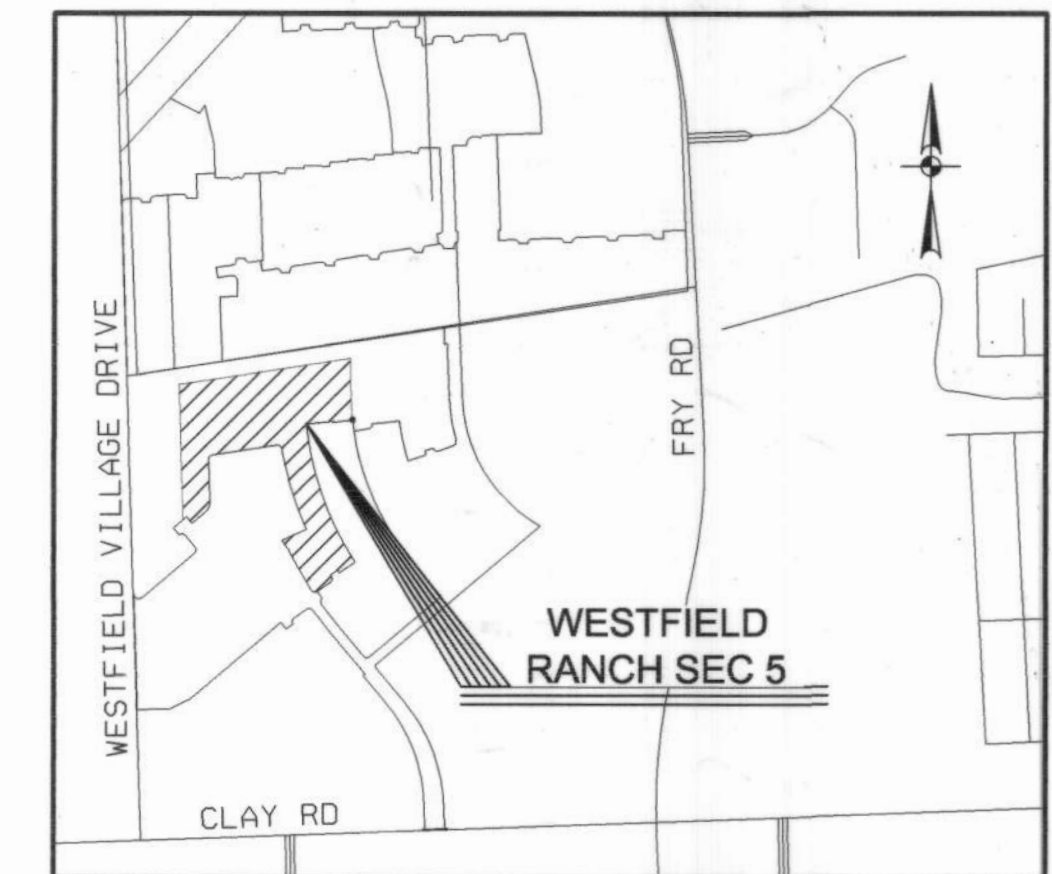

MAP REF: KEY MAP 446F  
ZIP CODE: 77449

LEGEND

- FOUND 5/8" IRON ROD (WINDROSE)
- SET 5/8" IRON ROD (PD)
- AC = ACRE
- AE = AERIAL EASEMENT
- SSE = SANITARY SEWER EASEMENT
- STM SE = STORM SEWER EASEMENT
- WLE = WATER LINE EASEMENT
- DE = DRAINAGE EASEMENT
- UE = UTILITY EASEMENT
- BL = BUILDING LINE
- R = RADIUS
- ROW = RIGHT-OF-WAY
- SF = SQUARE FEET
- GBL = GARAGE BUILDING LINE
- HCMR = HARRIS COUNTY MAP RECORDS
- HCDR = HARRIS COUNTY DEED RECORDS
- HCOPRRP = OFFICIAL PUBLIC RECORDS OF REAL PROPERTY
- HCFCD = HARRIS COUNTY FLOOD CONTROL DISTRICT
- OPRRPHC = OFFICIAL PUBLIC RECORDS OF HARRIS COUNTY TEXAS
- HCCF NO. = HARRIS COUNTY CLERK'S FILE NUMBER

# ADDRESS MAP FOR WESTFIELD RANCH SEC 5

A SUBDIVISION OF 14.938 ACRES  
LOCATED IN THE H.&T.C.R.R. CO. SURVEY,  
ABSTRACT NO. 436  
HARRIS COUNTY, TEXAS

74 LOTS 1 RESERVE 3 BLOCKS  
SCALE: 1" = 60' DECEMBER 2019

OWNER:

WOODMERE DEVELOPMENT CO., LTD.,  
A TEXAS LIMITED PARTNERSHIP  
15915 KATY FREEWAY, #405,  
HOUSTON, TEXAS 77094



HOUSTON | SAN ANTONIO | AUSTIN | FORT WORTH | DALLAS  
10350 RICHMOND AVE, STE 200 | HOUSTON, TX 77042 | 713.428.2400  
TBPE FIRM REGISTRATION #470 | TBPLS FIRM REGISTRATION #10193974



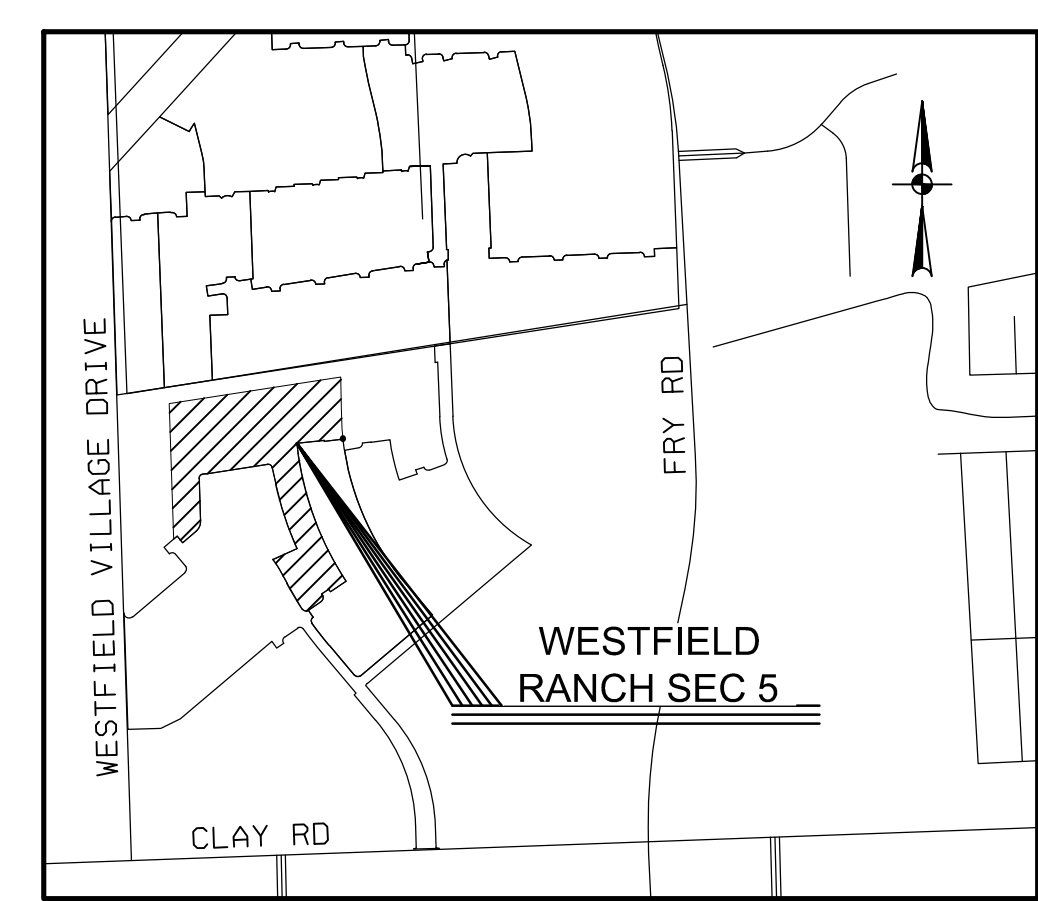
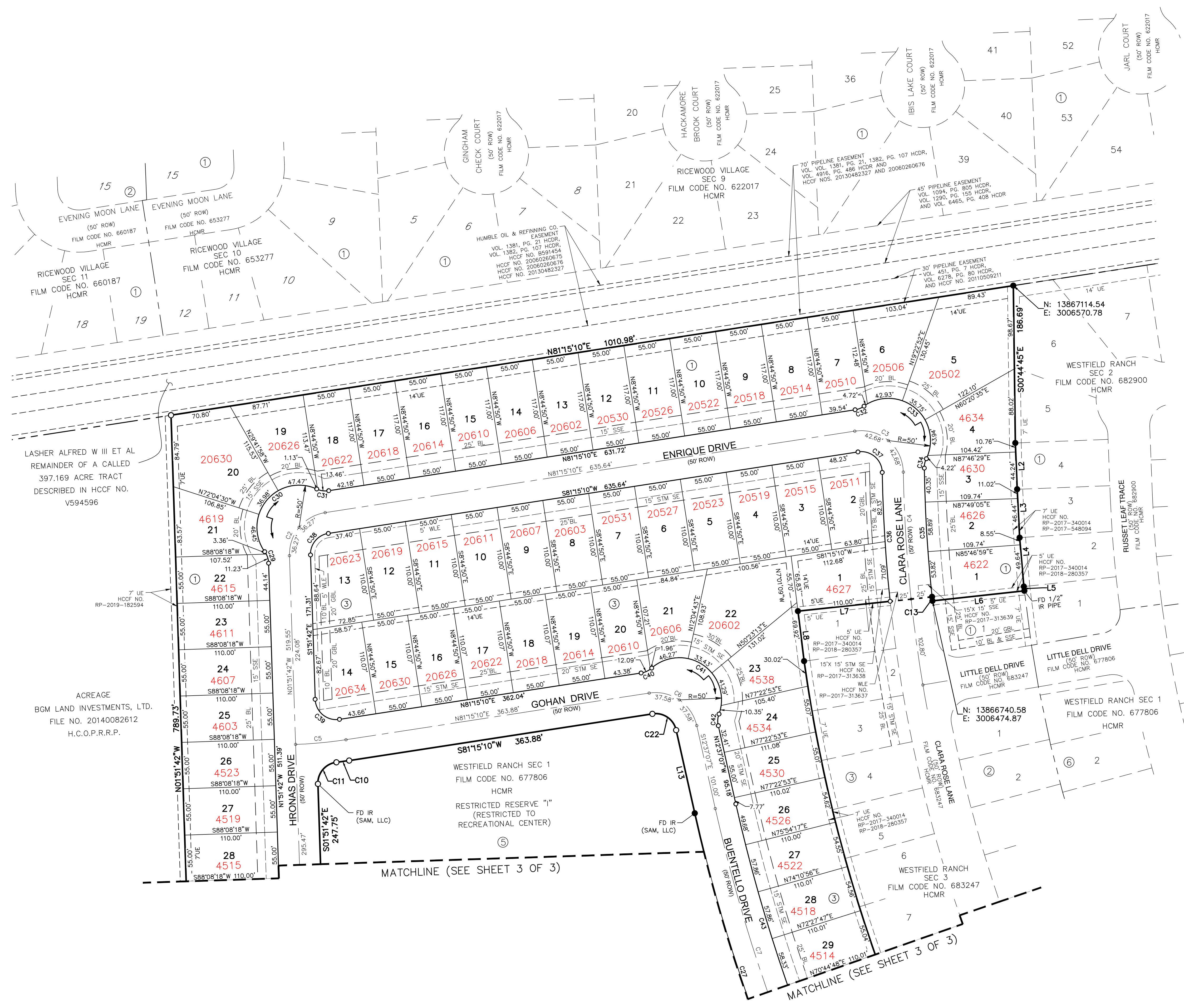

MAP REF: KEY MAP 446F  
ZIP CODE: 77449

**LEGEND**

- FOUND 5/8" IRON ROD (WINDROSE)
- SET 5/8" IRON ROD (PD)
- AC = ACRE
- AE = AERIAL EASEMENT
- SSE = SANITARY SEWER EASEMENT
- STM SE = STORM SEWER EASEMENT
- WLE = WATER LINE EASEMENT
- DE = DRAINAGE EASEMENT
- UE = UTILITY EASEMENT
- BL = BUILDING LINE
- R = RADIUS
- ROW = RIGHT-OF-WAY
- SF = SQUARE FEET
- GBL = GARAGE BUILDING LINE
- HCMR = HARRIS COUNTY MAP RECORDS
- HCDR = HARRIS COUNTY DEED RECORDS
- HCOPRRP = OFFICIAL PUBLIC RECORDS OF REAL PROPERTY
- HCFCOD = HARRIS COUNTY FLOOD CONTROL DISTRICT
- OPRRPHC = OFFICIAL PUBLIC RECORDS OF HARRIS COUNTY TEXAS
- HCCF NO. = HARRIS COUNTY CLERK'S FILE NUMBER

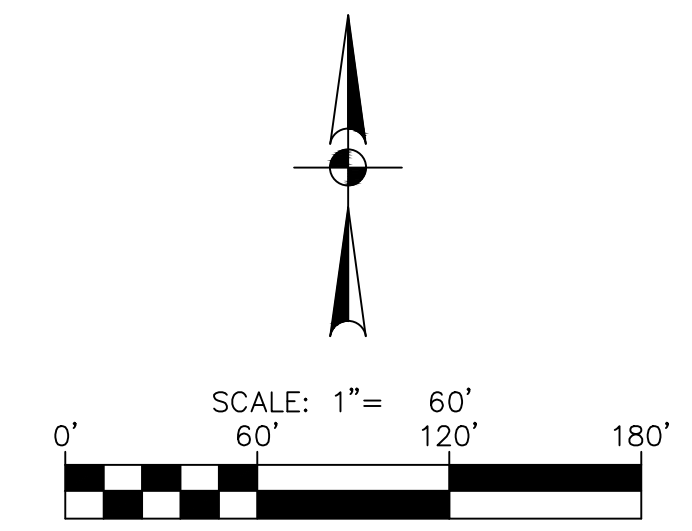

**ADDRESS MAP FOR  
WESTFIELD  
RANCH SEC 5**

A SUBDIVISION OF 14.938 ACRES  
LOCATED IN THE H.&T.C.R.R. CO. SURVEY,  
ABSTRACT NO. 436  
HARRIS COUNTY, TEXAS

74 LOTS 1 RESERVE 3 BLOCKS  
SCALE: 1" = 60' DECEMBER 2019

OWNER:  
WOODMERE DEVELOPMENT CO., LTD.,  
A TEXAS LIMITED PARTNERSHIP

ADDRESS:  
15915 KATY FREEWAY, #405,  
HOUSTON, TEXAS 77094



HOUSTON | SAN ANTONIO | AUSTIN | FORT WORTH | DALLAS  
10350 RICHMOND AVE, STE 200 | HOUSTON, TX 77042 | 713.428.2400  
TBPB FIRM REGISTRATION #470 | TBPBS FIRM REGISTRATION #10193974

Date: Mar 06, 2020, 10:53am User: JD, CM:mfz  
 File: K:\Projects\1505\08\20\2-0 Design\2-3 Plan\2-3-2 Final\200305 Address & Marketing Exhibit\PI-4060920\_FINAL\_R1.dwg



CURVE TABLE				
CURVE #	RADIUS	DELTA	CHORD BEARING	CHORD LENGTH
C1	50.00'	51°39'00"	N23°57'47"E	43.56'
C2	50.00'	83°06'52"	N39°41'44"E	66.34'
C3	50.00'	97°48'37"	S49°50'32"E	75.36'
C4	1683.00'	5°08'24"	N3°30'25"W	150.93'
C5	500.00'	6°53'08"	N84°41'44"E	60.05'
C6	50.00'	86°07'43"	N55°40'59"W	68.28'
C7	1953.00'	11°24'28"	S18°19'21"E	388.20'
C8	1950.00'	5°36'25"	S26°49'32"E	190.75'
C9	1953.02'	3°04'47"	S31°09'53"E	104.97'
C10	525.00'	1°40'11"	S82°05'15"W	15.30'
C11	25.00'	84°47'03"	S40°31'49"W	33.71'
C12	75.00'	51°39'00"	S23°57'47"W	65.34'
C13	1658.00'	0°09'58"	N6°09'36"W	4.81'
C14	1818.00'	25°14'21"	S20°34'51"E	794.38'
C15	1928.02'	0°29'50"	N32°56'56"W	16.73'
C16	1977.88'	0°19'42"	S32°52'22"E	11.33'
C17	25.00'	88°34'11"	S11°14'53"W	34.91'
C18	25.00'	91°22'03"	N78°47'00"W	35.77'
C19	2120.00'	4°41'59"	N30°44'59"W	173.85'
C20	277.00'	12°51'56"	N34°49'58"W	62.07'
C21	1978.00'	11°24'18"	N18°19'26"W	393.08'
C22	25.00'	86°07'43"	N55°40'59"W	34.14'
C23	1925.00'	5°36'25"	S26°49'32"E	188.31'
C24	1928.02'	3°04'32"	S31°09'45"E	103.48'
C25	1978.02'	3°05'02"	N31°10'00"W	106.46'
C26	1975.00'	5°36'24"	N26°49'32"W	193.19'
C27	1978.00'	11°24'18"	N18°19'26"W	393.08'
C28	25.00'	51°39'00"	N23°57'47"E	21.78'
C29	25.00'	33°26'21"	N18°34'53"W	14.38'
C30	50.00'	149°59'34"	N39°41'44"E	96.59'
C31	25.00'	33°26'21"	S82°01'40"E	14.38'
C32	25.00'	26°28'30"	N68°00'55"E	11.45'
C33	50.00'	150°45'03"	S49°50'49"E	96.76'
C34	25.00'	26°18'58"	S12°22'14"W	11.38'
C35	1658.00'	5°17'21"	S3°25'56"E	153.00'
C36	1708.00'	5°08'24"	N3°30'25"W	153.17'
C37	25.00'	97°48'37"	N49°50'32"W	37.68'
C38	25.00'	83°06'52"	S39°41'44"W	33.17'
C39	25.00'	96°53'08"	S50°18'16"E	37.41'
C40	25.00'	32°11'28"	N65°09'25"E	13.86'
C41	50.00'	150°30'40"	S55°40'59"E	96.71'
C42	25.00'	32°11'28"	S3°28'37"W	13.86'
C43	1928.00'	11°24'28"	S18°19'21"E	383.23'

LINE TABLE		
LINE #	BEARING	LENGTH
L1	S49°47'17"W	25.75'
L2	S21°31'31"E	55.00'
L3	S2°52'16"E	57.46'
L4	S4°57'35"E	58.19'
L5	S7°20'12"E	5.11'
L6	S83°45'25"W	109.89'
L7	S83°55'23"W	160.00'
L8	S7°01'09"E	59.79'
L9	S56°48'09"W	110.04'
L10	S56°57'47"W	50.00'
L11	S55°31'58"W	92.06'
L12	N28°23'59"W	101.00'
L13	N12°37'07"W	101.10'
L14	S49°47'17"W	102.41'
L15	N40°12'43"W	50.00'

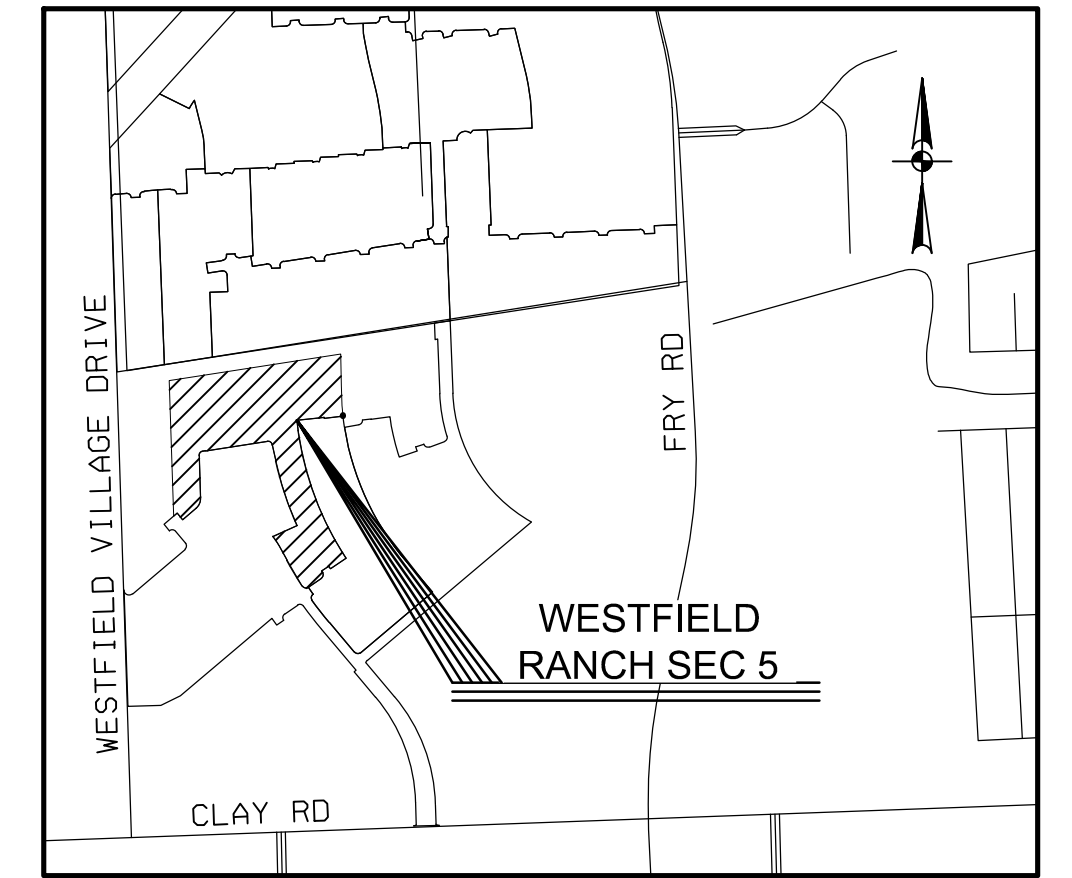
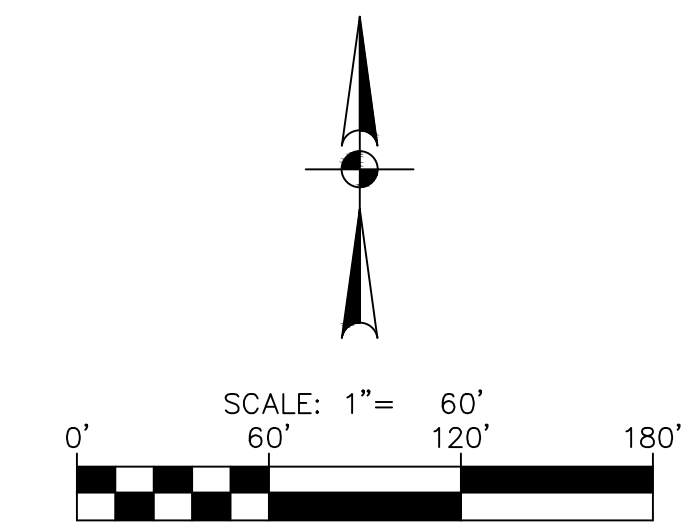

MAP REF: KEY MAP 446F  
ZIP CODE: 77449

**LEGEND**

- FOUND 5/8" IRON ROD (WINDROSE)
- SET 5/8" IRON ROD (PD)
- AC = ACRE
- AE = AERIAL EASEMENT
- SSE = SANITARY SEWER EASEMENT
- STM SE = STORM SEWER EASEMENT
- WLE = WATER LINE EASEMENT
- DE = DRAINAGE EASEMENT
- UE = UTILITY EASEMENT
- BL = BUILDING LINE
- R = RADIUS
- ROW = RIGHT-OF-WAY
- SF = SQUARE FEET
- GBL = GARAGE BUILDING LINE
- HCMR = HARRIS COUNTY MAP RECORDS
- HCDR = HARRIS COUNTY DEED RECORDS
- HCOFRRP = OFFICIAL PUBLIC RECORDS OF REAL PROPERTY
- HCFCD = HARRIS COUNTY FLOOD CONTROL DISTRICT
- OPRRPHC = OFFICIAL PUBLIC RECORDS OF HARRIS COUNTY TEXAS
- HCCF NO. = HARRIS COUNTY CLERK'S FILE NUMBER

**RESERVE**

- (A) RESTRICTED RESERVE "A"  
(RESTRICTED TO LANDSCAPE / OPEN SPACE PURPOSES ONLY)  
0.209 AC. 9,100 SQ.FT.

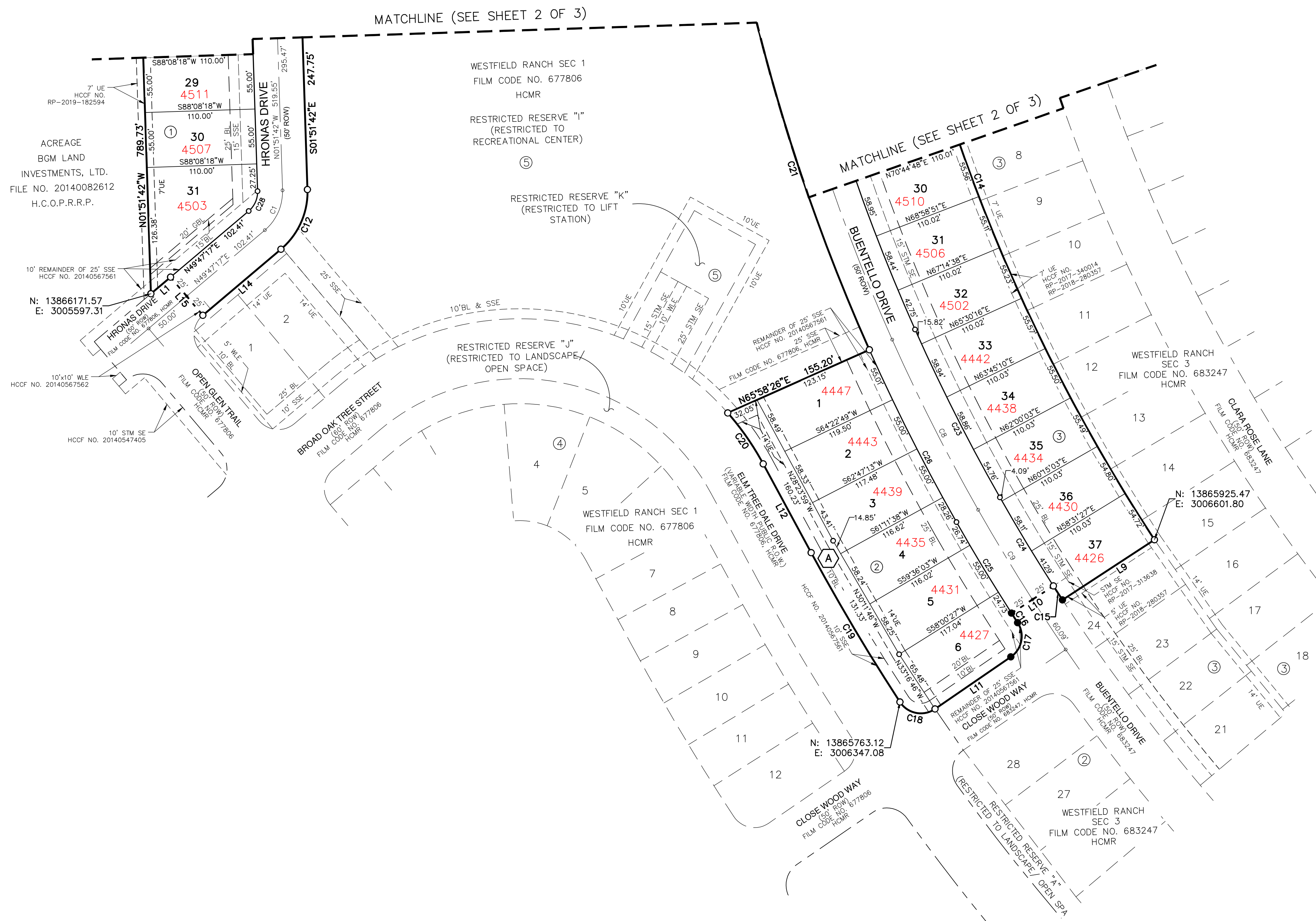

# ADDRESS MAP FOR WESTFIELD RANCH SEC 5

A SUBDIVISION OF 14.938 ACRES  
LOCATED IN THE H.&T.C.R.R. CO. SURVEY,  
ABSTRACT NO. 436  
HARRIS COUNTY, TEXAS

74 LOTS 1 RESERVE 3 BLOCKS  
SCALE: 1" = 60' DECEMBER 2019

OWNER:  
WOODMERE DEVELOPMENT CO., LTD.,  
A TEXAS LIMITED PARTNERSHIP

ADDRESS:  
15915 KATY FREEWAY, #405,  
HOUSTON, TEXAS 77094



HOUSTON | SAN ANTONIO | AUSTIN | FORT WORTH | DALLAS  
10350 RICHMOND AVE, STE 200 | HOUSTON, TX 77042 | 713.428.2400  
TBPE FIRM REGISTRATION #470 | TBPLS FIRM REGISTRATION #10193974

Date: Mar 06, 2020, 10:45am User: JD, CM, mdf  
 File: K:\Projects\1506\1506\_2019\_02\_03\_Design\2-3\_Bldg\2-3-2\_Final\200305 Address & Marketing Exhibit\PI-4060920\_FINAL\_R1.dwg